

MODEL №: 3933

ISSUED: 01/87

REVISED: 16 Jan 2013

ANCHOR FOR 3/4"- 1" (19-25) THICK PARTITION MOUNTED BARS WITH SNAP-ON FLANGE COVER

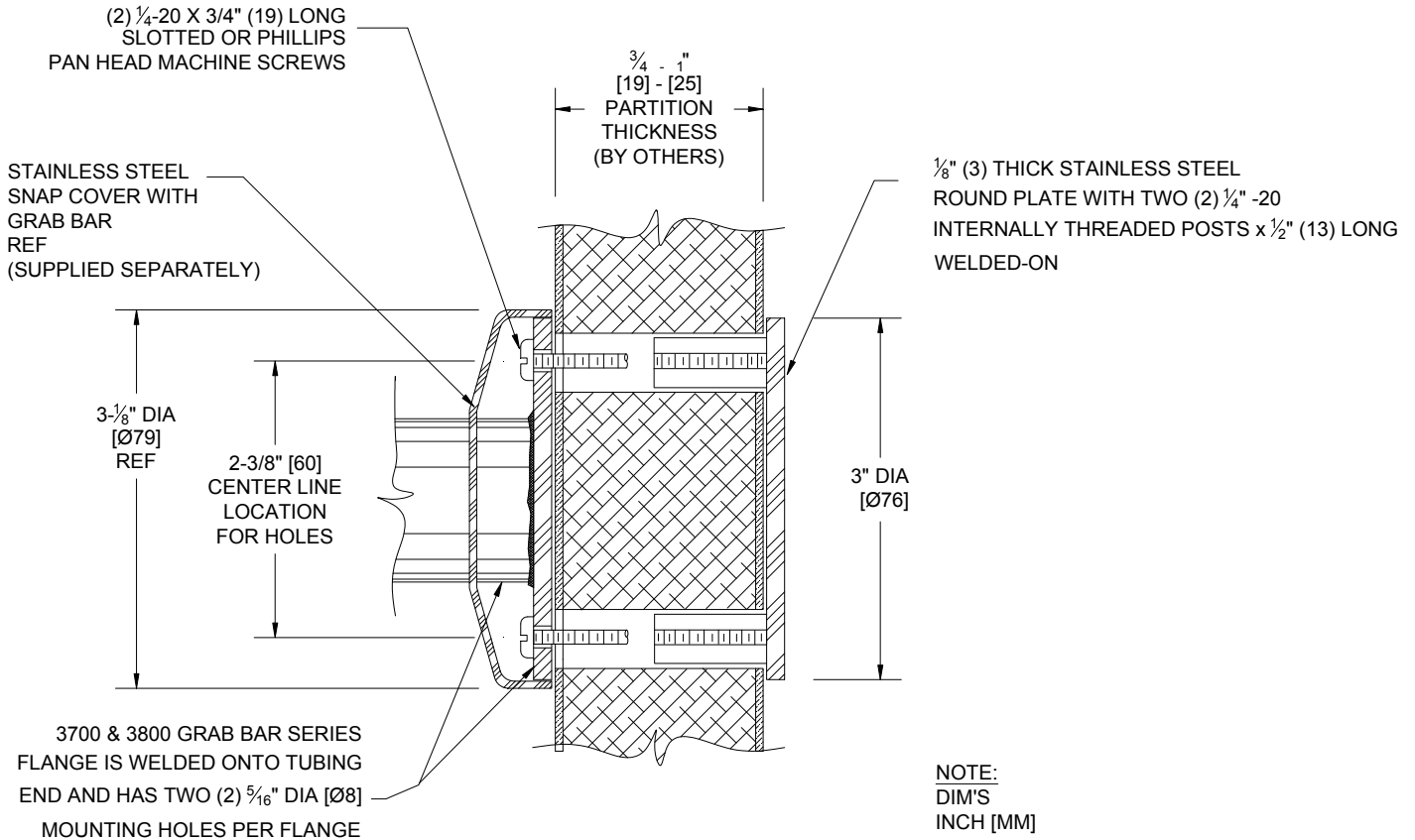

SPECIFICATION

Anchor for 3/4"- 1" (19-25) Thick Partition Mounted Grab Bars with Snap-On Flange Covers shall be type 304 stainless steel alloy 18-8 plate 1/8" (3) thick with two (2) 1/4-20 internally threaded posts welded onto concealed side. Exposed side of plate shall have a satin finish. Anchor kit shall contain one (1) Plate and two (2) 1/4-20 x 3/4" (19) long Phillips or slotted pan head machine screws. Specify one (1) kit per flange.

INSTALLATION

Place grab bar on partition at desired location and mark mounting hole locations. Drill 3/8" diameter (Ø10) holes through the partition at marked locations. Place anchor at far sides of partition and mount grab bar to it on near side with 1/4-20 machine screws (provided) to complete installation. Refer to grab bar specification for correct procedure and strength data. For compliance with 2010 ADA Accessibility Standards mount unit so that top of horizontal grab bar is 33" (838) minimum above finished floor (AFF) to 36" (914) max AFF.