

MODEL No: 046921-9

ISSUED: 1-87

REVISED: 3-04

SURFACE MOUNTED ROLL PAPER TOWEL DISPENSER AND DISPOSAL

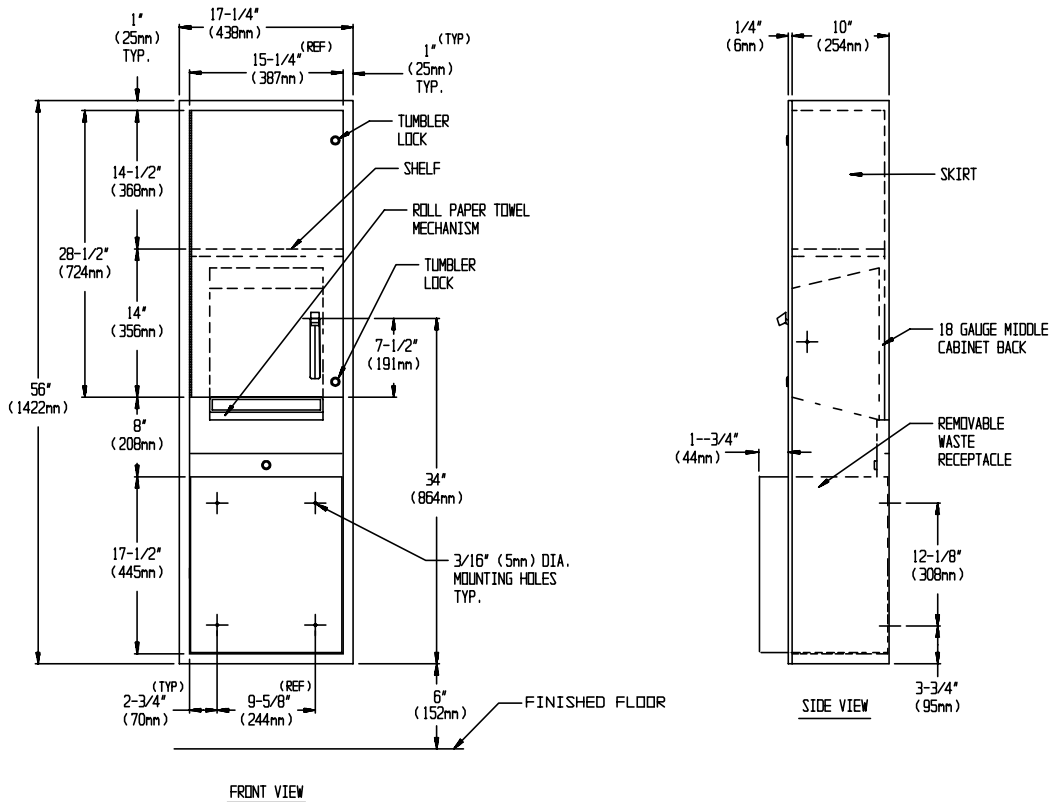

SPECIFICATION

Surface Mounted Roll Paper Towel Dispenser and Disposal shall hold and dispense one 8" or 9" wide standard towel roll up to 800 ft. (244m) long and one stub roll up to 4" (102mm) diameter and shall have a waste capacity of 13.3 gal (50.4 liters). Unit frame, waste container and cabinet shall be fabricated of alloy 18-8 stainless steel, type 304, N^o22 gauge; towel dispenser door shall be same grade N^o18 gauge; unit back plate for mechanism shall be fabricated of N^o18 gauge; all exposed surfaces shall have N^o4 satin finish protected by a plastic PVC film easily removed after installation. Towel dispensing slot shall be smooth and burr-free for snag-free dispensing and user safety. Door shall be attached to cabinet at side with a full length 3/16" dia. stainless steel multi-staked piano hinge and be held closed with a tumbler lock keyed alike to other ASI Washroom Equipment. Waste container shall have hemmed edges for safety and shall be retained by a tumbler lock keyed alike to other ASI Washroom Equipment. Face trim shall be 1" (25mm) wide formed from one piece with no mitres, welding or open seams and have 1/4" (6mm) square return to surrounding surface mounted collar. Structural assembly of all components shall be of welded construction. Cabinet shall have no exposed fastening devices or spot welded seams. Unit shall be supplied with SM collar to convert to surface mounting.

INSTALLATION

Unit is surface mounted on wall using N^o10 self tapping screws (by others) through concealed mounting holes provided. For compliance with ADA Accessibility Guidelines, unit should be installed so that towel dispenser lever is 54" (1372mm) maximum above finished floor (AFF) if clear floor side reach access is provided or 48" (1219mm) maximum AFF if clear floor forward reach access only is provided. SM collar is installed on cabinet prior to mounting on wall following procedure described on SM Collar Data Sheet.

OPERATION

Towels are fed by lever action until supply is depleted. Towel feed length is adjustable for economy by pin (supplied) limiting of lever stroke length. Unit may be reloaded with a full roll to automatically start when finished with an existing partial roll. Waste container is emptied manually on cycle determined by maintenance needs.